

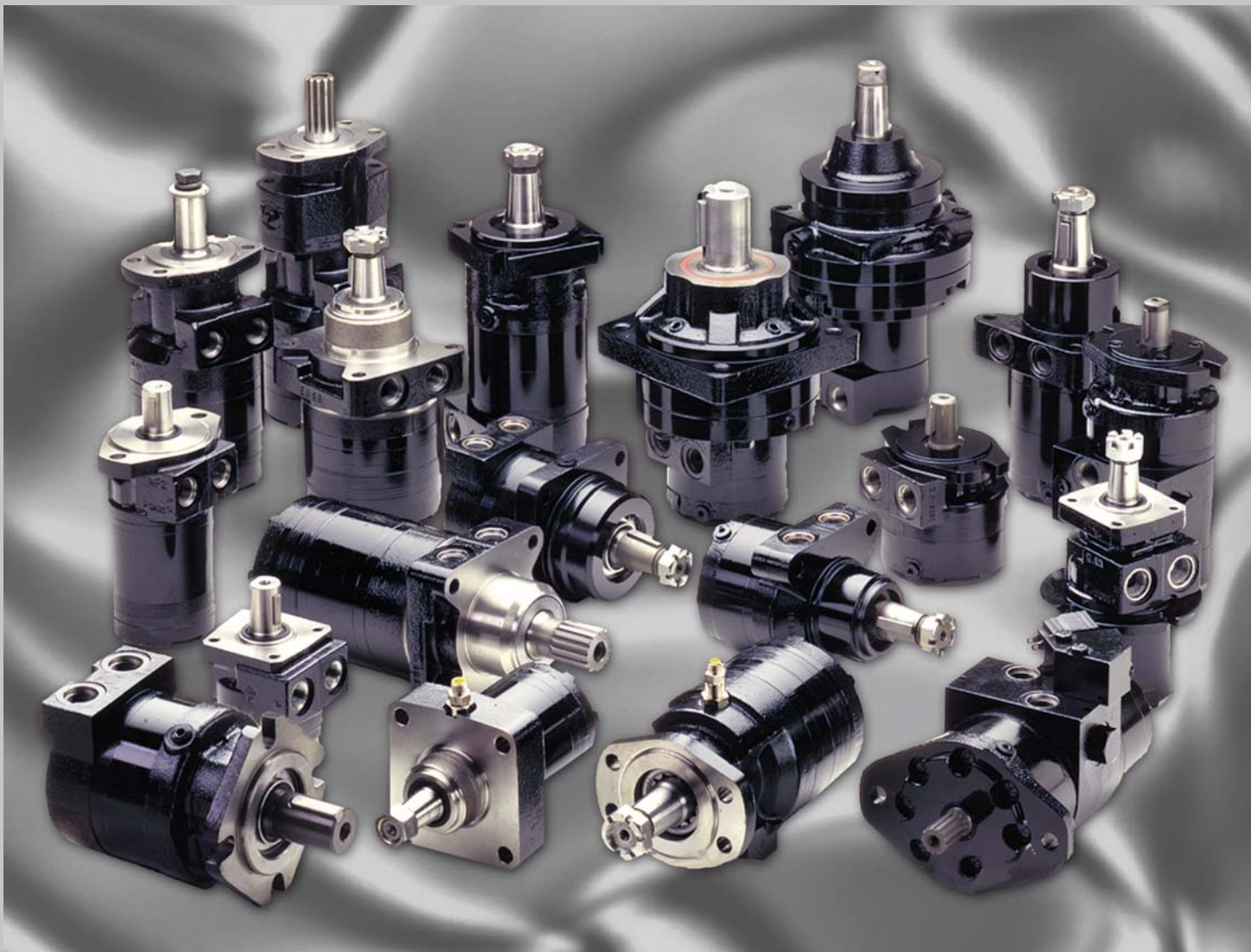

Torqmotor™ **Series TE / TJ**

max. 14 kW

Catalogue HY11-3205/EU
Ed. 03 / 2004



DE Hinweis

Die in diesem Katalog oder in Form anderer Informationen durch die Parker Hannifin GmbH, ihre Niederlassungen, Vertriebsbüros oder ihre autorisierten Werksvertretungen gemachten Angaben sind für Anwender mit Sachkenntnissen bestimmt. Vom Anwender ist eine Überprüfung der über das ausgewählte Produkt gemachten Angaben auf Eignung für die geforderten Funktionen erforderlich. Bedingt durch die unterschiedlichen Aufgaben und Arbeitsabläufe in einem System muss der Anwender prüfen und sicherstellen, dass durch die Eigenschaften des Produkts alle Forderungen hinsichtlich Funktion und Sicherheit des Systems erfüllt werden.

UK Note

This document and other information from Parker Hannifin GmbH, its subsidiaries, sales offices and authorized distributors provide product or system options for further investigation by users having technical expertise. Before you select or use any product or system it is important that you analyse all aspects of your application and review the information concerning the product or system in the current product catalogue. Due to the variety of operating conditions and applications for these products or systems, the user, through his own analysis and testing, is solely responsible for making the final selection of the products and systems and assuring that all performance and safety requirements of the application are met. The products are subject to change by Parker Hannifin GmbH at any time without notice.

FR Note

Les indications données dans le présent catalogue ainsi que toutes autres informations fournies par Parker Hannifin GmbH, ses succursales, ses bureaux de vente ou ses représentations d'usine autorisées sont destinées aux utilisateurs ayant des connaissances techniques en la matière. L'utilisateur devra procéder à une vérification des indications faites sur le produit sélectionné pour savoir s'il est bien approprié aux fonctions demandées. Dû aux conditions environnementales variées dans les quelles ces composants et ces systèmes doivent opérer, l'utilisateur doit vérifier et s'assurer que les propriétés du produits répondent bien à toutes les exigences relatives au fonctionnement et à la sécurité du système.

IT Avvertenza

Le indicazioni fatte nel presente catalogo o sotto forma di altre informazioni dalla Parker Hannifin GmbH, dalle sue filiali, uffici di vendita o dalle sue consociate autorizzate, sono destinate a utenti con conoscenze tecniche. L'utente è tenuto a verificare che le indicazioni fatte sul prodotto scelto siano conformi alle funzioni richieste. A causa delle diverse applicazioni e condizioni d'impiego, l'utente deve verificare e assicurare che le proprietà del prodotto soddisfino tutte le esigenze relative al funzionamento e alla sicurezza del sistema.

Description DE	UK	FR	IT	Page
Merkmale	Features	Caractéristique	Prestazioni	4
Kenndaten	Performance	Puissance	Carratteristiche	5
Gehäuse	Housing	Carter	Scatola	6
Endanschluss	Rear Ports	Orifices arrières	Connessioni posteriori	8
Abtriebswelle	Coupling shaft	Arbre	Giunto	9
Anschlüsse	Ports	Orifices	Connessione	10
Diagramme	Diagrams	Diagrammes	Diagrammi	11
Beispiel	Example	Exemple	Esempio	13
Lebensdauer	Life Time	Durée	Durata	14
Bestellschlüssel	Ordering Code	Système de commande	Codice di ordinazione	15
Schockventil	Crossover relief valve	Valve antichoc	Valvola di soprapressione	17
Spülventil	Hot oil shuttle valve	Valve de rinçage	Valvola selettiva	18
Drehzahl-Sensor	Speed sensor	Compte-tours	Contagiri	19
Lamellenbremse	Multiple disc brake	Frein multi-disque	Freno multidisco	21
Betrieb	Operation	Mise en service	Istuzioni pez l' uso	22
Produktübersicht	Motor range	Gamme de moteurs	Gamma di motori	23

Features

- **Langsamlaufender Gerotor-Motor**
- **Spezielle Orbital-Steuerung**
Geringe interne Leckage
Hoher volumetrischer Wirkungsgrad
- **Rollen im Rotorset**
Reduzierte Reibung
Lange Lebensdauer
- **Patentierte Hochdruckwellendichtung**
Keine Leckölleitung
Keine Rückschlagventile
- **Vielzahl von Varianten**
Großer Einsatzbereich

Torqmotor Series TE / TJ

- **Low Speed Gerotor Motor**
- **Zero leak commutation valve**
For greater, more consistent
Volumetric efficiency
- **Roller vane rotor set**
Reduces friction and internal leakage
Maintaining efficiency throughout the life of the motor
- **Patented high-pressure shaft seal**
No check valves needed
No extra plumbing
- **Wide choice of displacement range, flange and shaft options**
Greater efficiency in systems design
to suit your application

Series TE

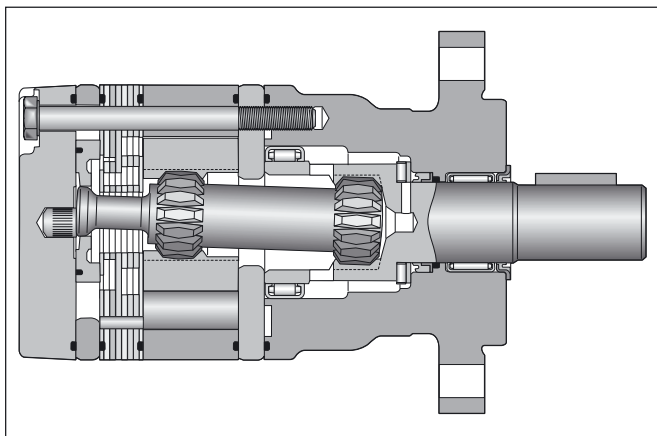

Series TJ

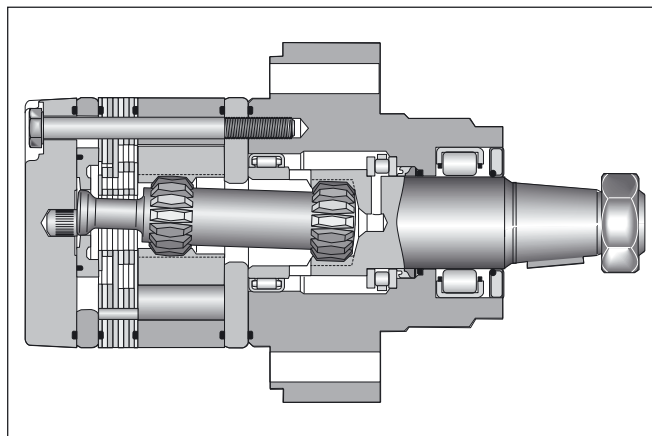

- **Moteur lent système Gerotor**
- **Une distribution orbitale particulière assure**
fuites internes minimales
rendements volumétriques élevés
- **Le rotor à rouleaux**
réduit les frottements
augmente la durée de vie
- **Par l'utilisation de joints d'arbre haute pression brevetés**
pas de conduite de drainage
pas de clapets anti-retour
- **Grâce à de nombreuses variantes**
larges domaines d'applications

- **Motore orbitale a bassa velocità**
- **Una particolare distribuzione orbitale assicura**
trafilamento ridotto elevato rendimento volumetrico
- **Con lo statore a rullo**
si riduce l'attrito interno
si mantiene nel tempo l'efficienza del motore
- **Una guarnizione di tenuta ad alta pressione brevettata elimina la necessità**
di una linea di drenaggio esterna e di valvole non ritorno
- **Un'ampia gamma di cilindrata, flangiature ed alberi**
consentono scelte adeguate ad ogni esigenza costruttiva

Drehzahl Speed Vitesse de rotation Velocità di rotazione	5...1160 rev/min
Schluckstrom Oil flow Débit d'huile Portata	max. 75 l/min
Eingangsdruck Supply pressure Pression entrée Pressione in entrata	max. 200 bar
Drehmoment Torque Couple Coppia	max. 550 Nm
Seitenlast Side load Charges latérales Carico radiale	TE = max. 7000 N TJ = max. 14000 N



Series TJ

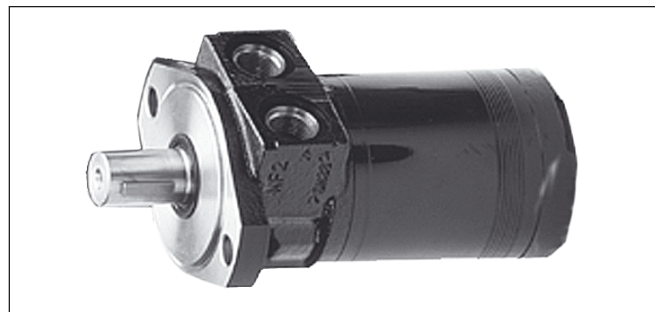
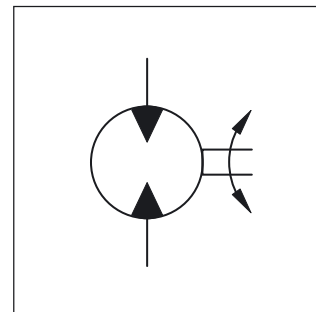

Series TE

Motor series TE / TJ	cm ³ /U cm ³ /rev	cont / int U/min rev/min	cont / int l/min	cont / int bar	max bar	cont / int Nm	cont / int KW	cont / int Nm
TE/TJ 36	36	930 / 1160	35 / 42	140 / 190	200	55 / 70	8,5	44 / 52
TE/TJ 45	41	810 / 990	35 / 42	140 / 190	200	70 / 100	10	44 / 64
TE/TJ 50	50	725 / 935	35 / 45	140 / 175	200	90 / 115	11	72 / 92
TE/TJ 65	66	705 / 940	45 / 60	140 / 175	200	125 / 160	15	100 / 128
TE/TJ 80	82	560 / 750	45 / 60	140 / 175	200	160 / 200	15	128 / 160
TE/TJ 100	98	470 / 630	45 / 60	140 / 175	200	190 / 240	15	152 / 192
TE/TJ 130	130	350 / 470	45 / 60	140 / 175	200	255 / 320	15	204 / 256
TE/TJ 165	163	280 / 375	45 / 60	140 / 175	200	310 / 395	15	248 / 316
TE/TJ 195	196	235 / 315	45 / 60	140 / 175	200	390 / 480	15	312 / 384
TE/TJ 230	228	265 / 330	60 / 75	120 / 150	200	380 / 480	15	304 / 384
TE/TJ 260	261	230 / 290	60 / 75	110 / 140	200	400 / 525	15	320 / 420
TE/TJ 295	293	200 / 255	60 / 75	100 / 130	200	410 / 520	13	328 / 416
TE/TJ 330	326	185 / 235	60 / 75	100 / 120	200	430 / 530	13	344 / 424
TE/TJ 365	370	150 / 200	60 / 75	95 / 110	200	467 / 558	11	373 / 446
TE/TJ 390	392	152 / 190	60 / 75	85 / 100	200	435 / 540	10	348 / 432

int. =

Intermittierende Werte maximal: 10% von jeder Betriebsminute.

Intermittent operation rating applies to 10% of every minute.

Fonctionnement interm.: 10% max. de chaque minute d'utilisation.

Servizio intermittente: 10% max di ogni minuto di utilizzazione.

Code C

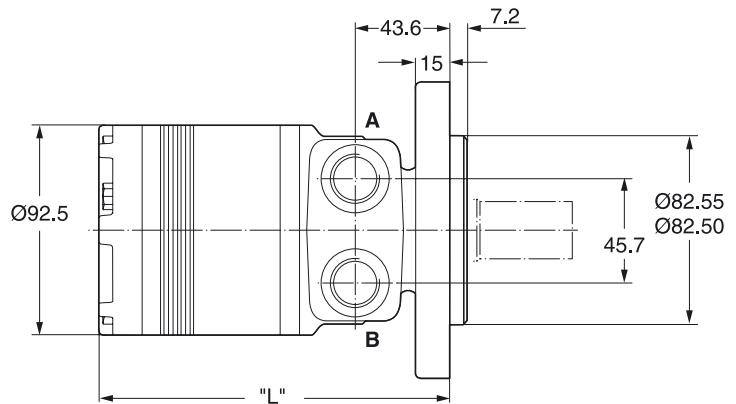
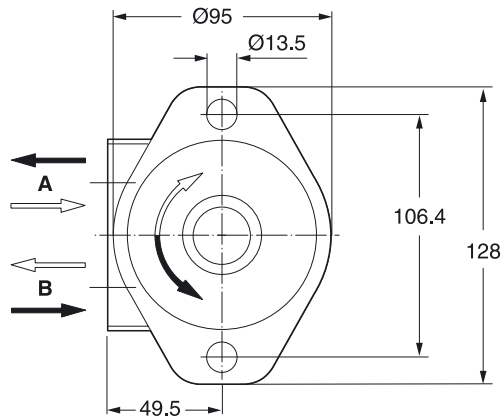

Code M

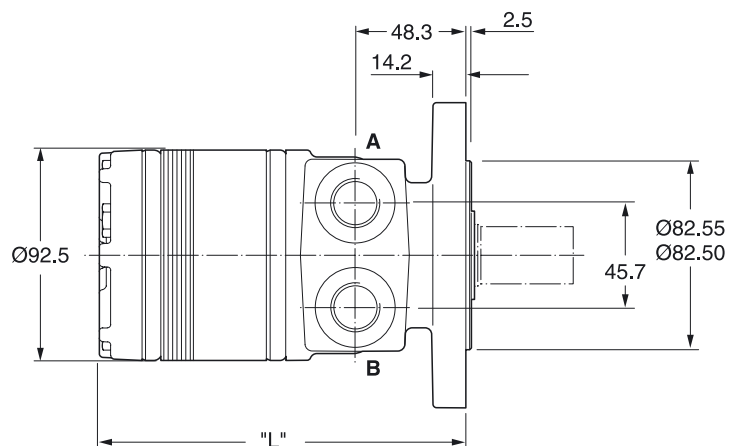
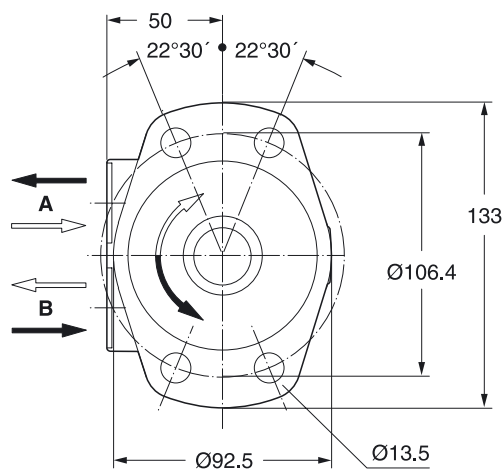

Code D

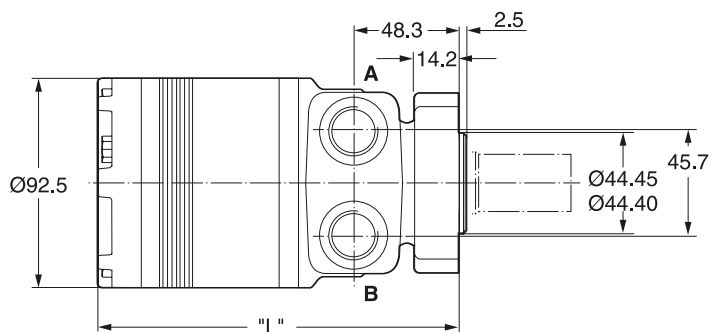
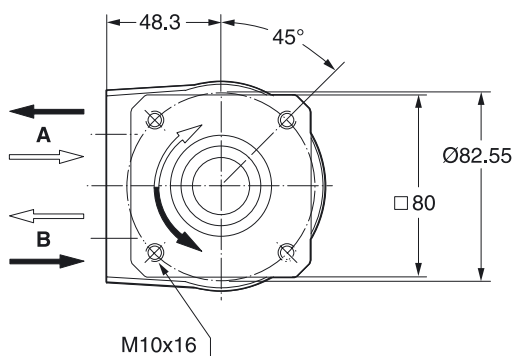

Gewicht / Weight	TE36	TE45	TE50	TE65	TE80	TE100	TE130	TE165	TE195	TE230	TE260	TE295	TE330	TE365	TE390
Poids / Peso [kg]	5.8	6.3	6.5	6.6	6.7	6.8	7.1	7.4	7.7	7.9	8.2	8.3	8.7	9.0	9.2
Code C "L" [mm]	128	131	133.1	136.1	139.5	142.5	148.8	155.2	161.5	167.9	174.2	180.6	186.9	195.1	199.9
Code M, D "L" [mm]	134	136	137.7	140.7	144	147	153.4	159.8	166.1	172.5	178.8	185.2	191.5	199.6	204.5

PI 3205 TE-TJ.PMD RH

Code L

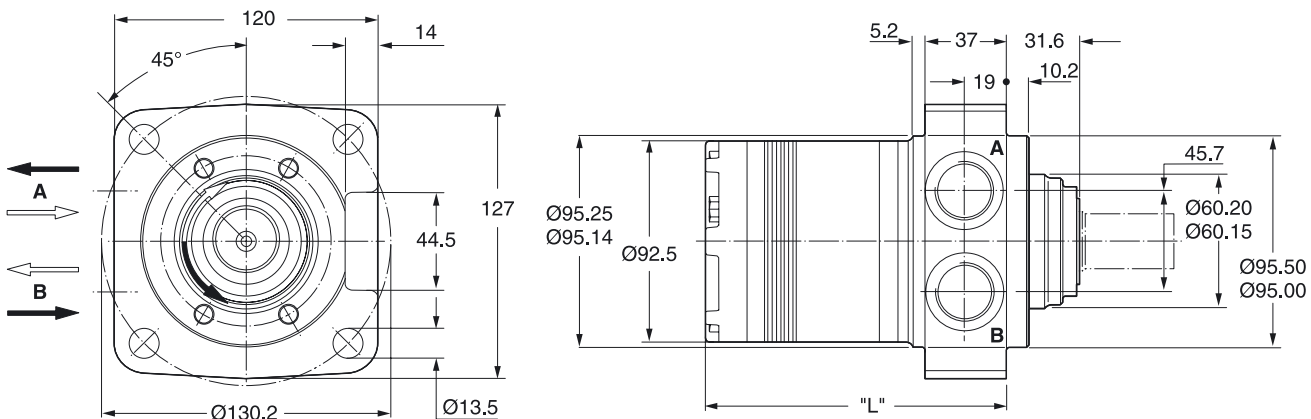

Gewicht / Weight	TE36	TE45	TE50	TE65	TE80	TE100	TE130	TE165	TE195	TE230	TE260	TE295	TE330	TE365	TE390
Poids / Peso [kg]	6.7	6.8	6.9	7.0	7.1	7.2	7.6	7.8	8.1	8.3	8.6	8.8	9.1	9.4	9.6
Code L "L" [mm]	105	107	108.8	111.8	115	118	124.5	130.8	137.1	143.6	149.9	156.3	162.6	170.7	175.6

Code H

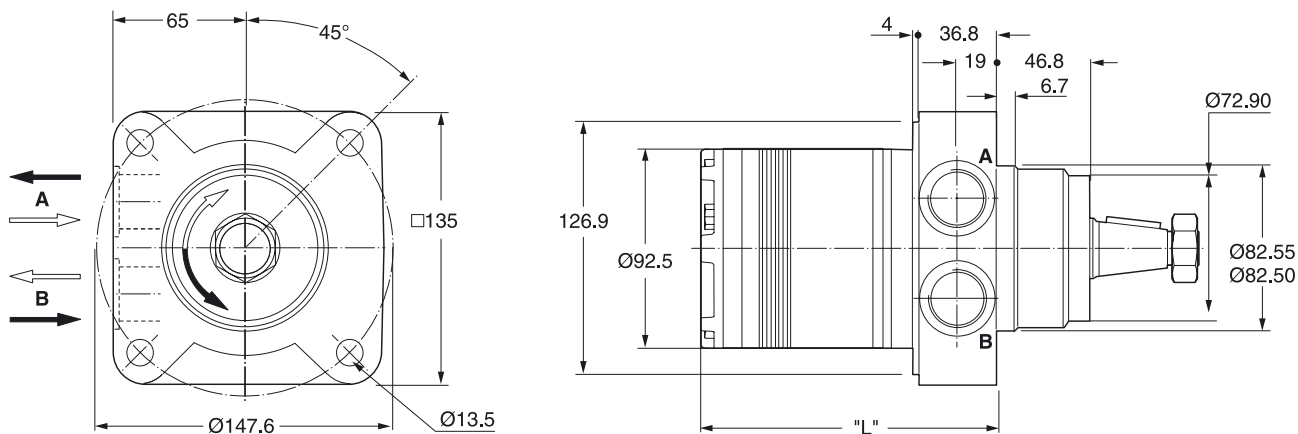

Gewicht / Weight	TJ36	TJ45	TJ50	TJ65	TJ80	TJ100	TJ130	TJ165	TJ195	TJ230	TJ260	TJ295	TJ330	TJ365	TJ390
Poids / Peso [kg]	6.7	6.8	6.9	7.0	7.1	7.2	7.6	7.8	8.1	8.3	8.6	8.8	9.1	9.4	9.6
Code H "L" [mm]	103	106	109	112	115	118	124	131	137	143	150	156	162	171	175

Code Y

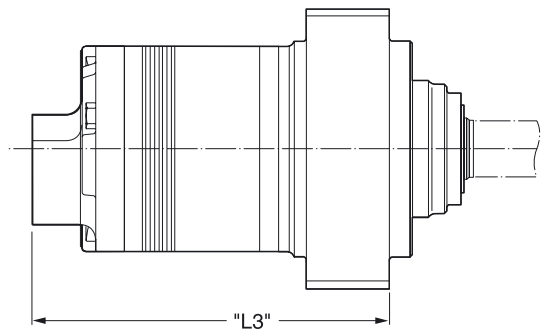
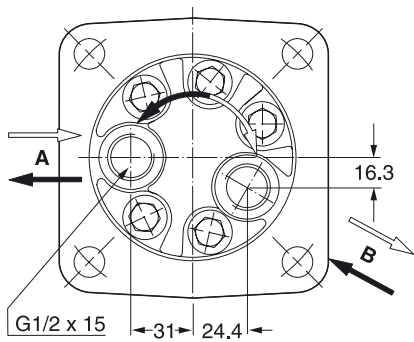
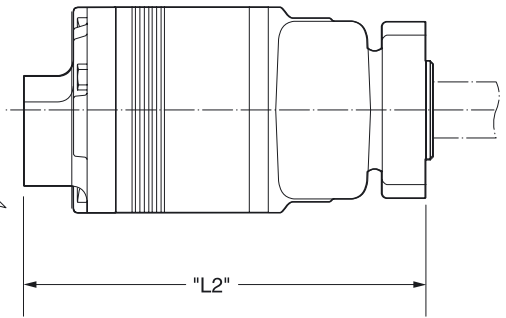
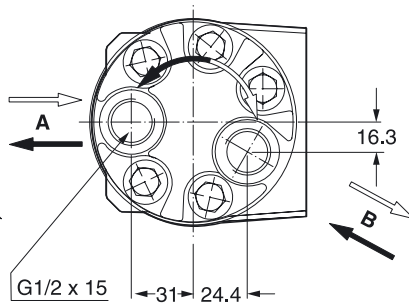
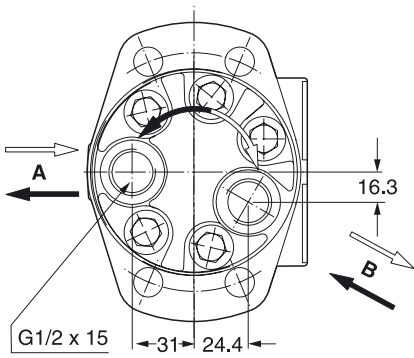
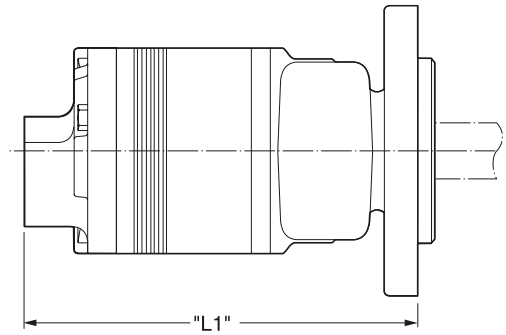
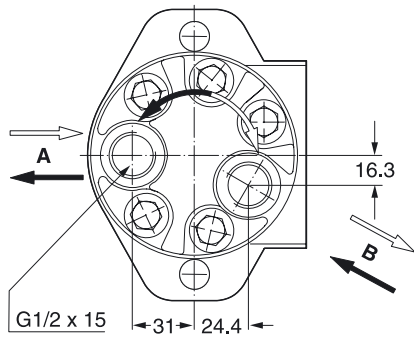

Gewicht / Weight		TE36	TE45	TE50	TE65	TE80	TE100	TE130	TE165	TE195	TE230	TE260	TE295	TE330	TE365	TE390
Poids / Peso [kg]		7.2	7.3	7.4	7.5	7.6	7.7	8.1	8.3	8.6	8.8	9.1	9.3	9.6	9.9	10.1
Code Y	"L1" [mm]	151	152	154	157	160	164	170	177	183	189	196	202	208	215.5	221
	"L2" [mm]	155	156	158	161	165	168	174	181	187	193	200	206	212	220	225
	"L3" [mm]	127	128	130	132	136	139	145	152	158	164	171	177	183	191.1	196

Code 08

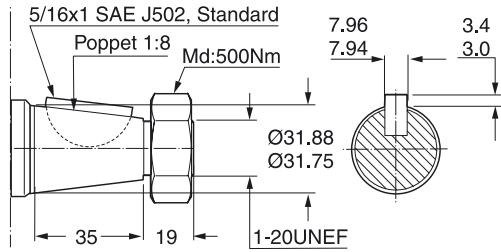

Code 10

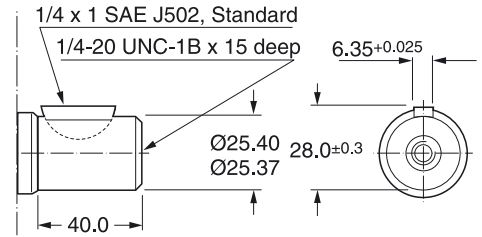

Code 12

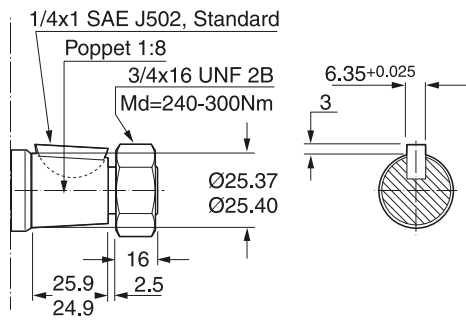

Code 25

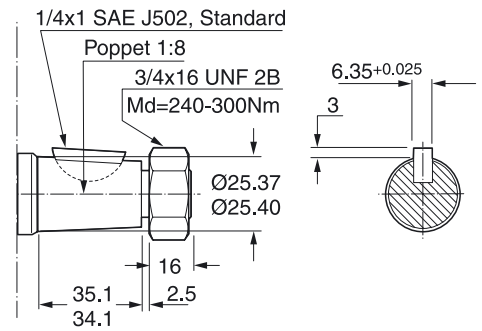

Code 26*

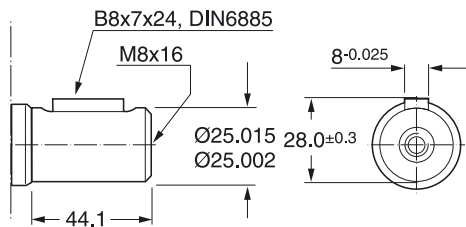

Code 41

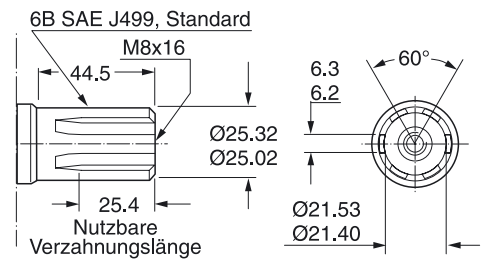

* Option AAMB = Rostfreie Ausführung
 Option AAMB = Version en acier inoxydable

/ Option AAMB = Stainless steel version
 / Opzione AAMB = Versione in acciaio inossidabile

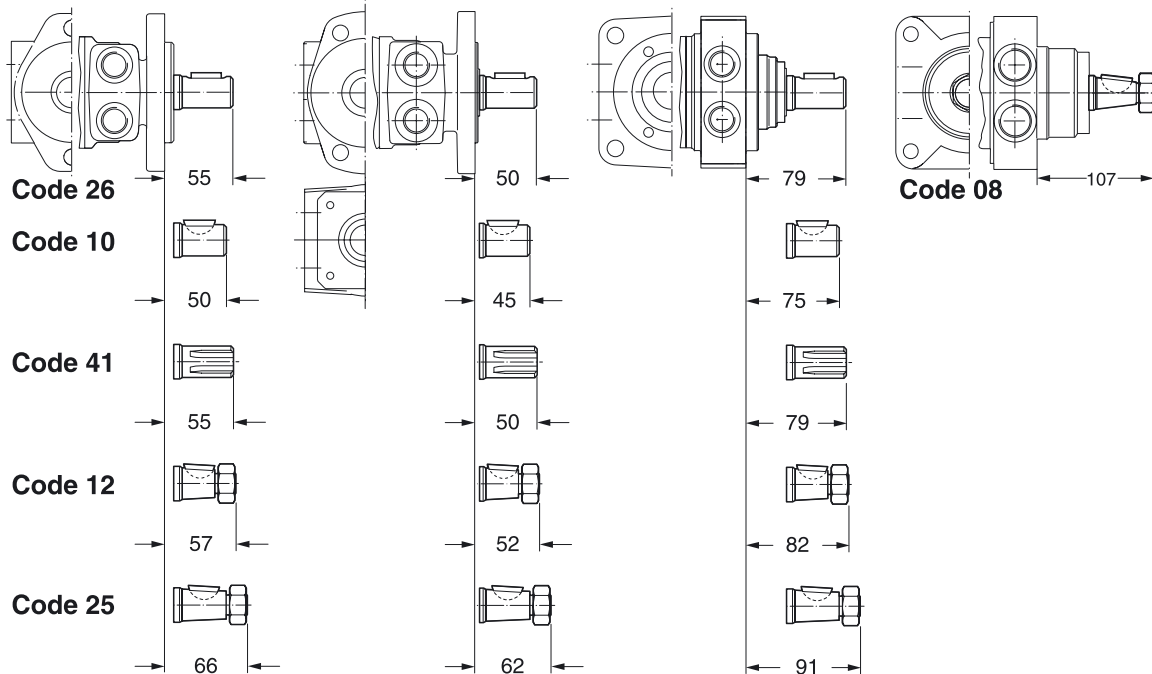

Code W

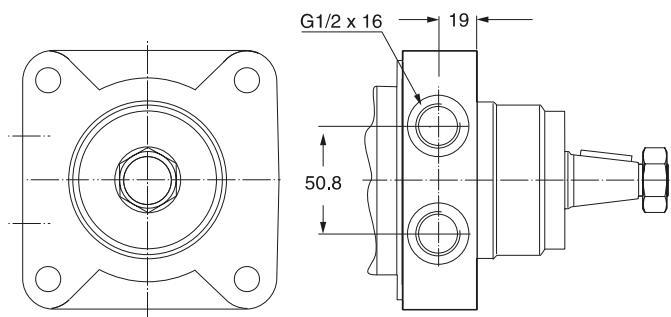
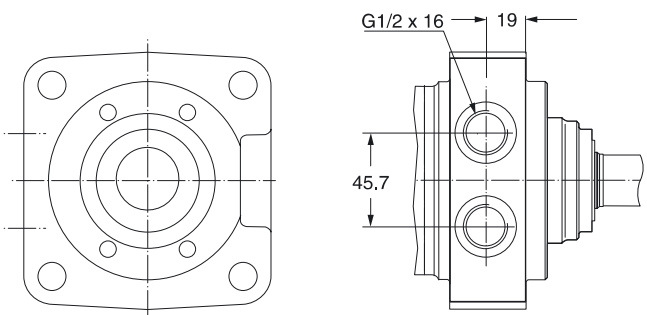
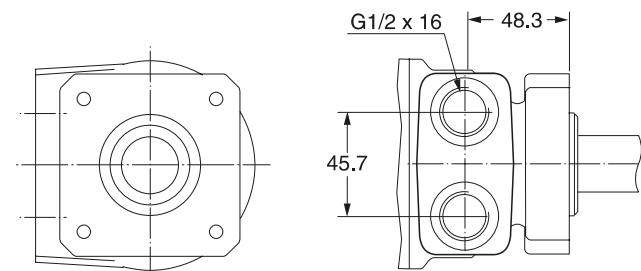
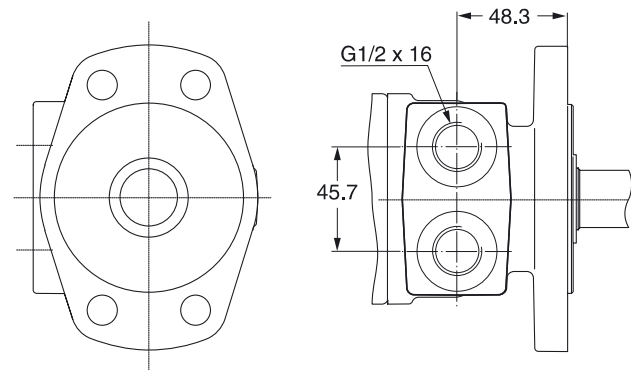
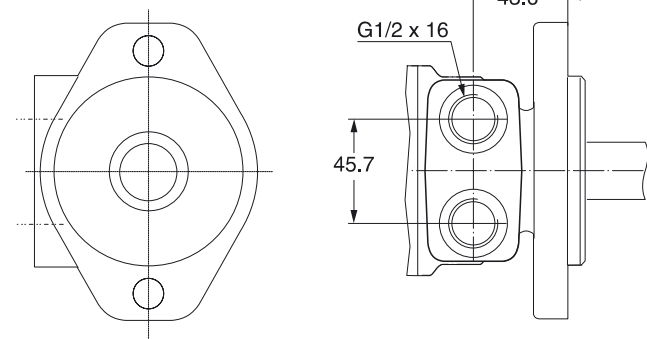

Code N

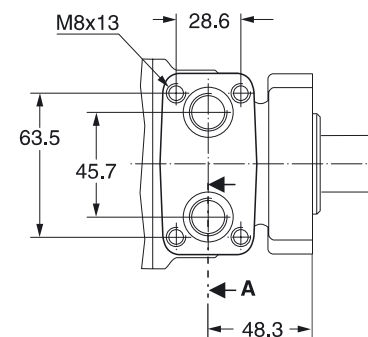
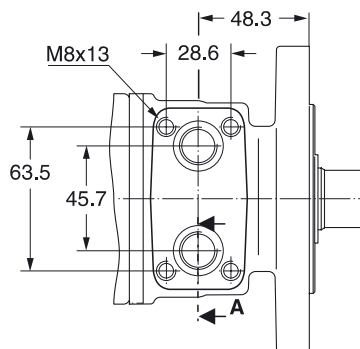
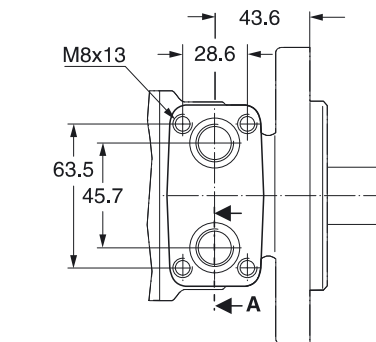

Section A

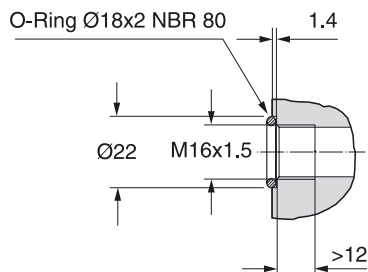

Zum Motor mit Universalanschluss werden 2 O-Ringe geliefert.

Motor with manifold mount is supplied with 2 O-rings.

Deux joints toriques sont livrés avec les moteurs au plan de raccordement universel.

Il blocchetto connessioni è corredato da 2 OR.

TE/TJ 36

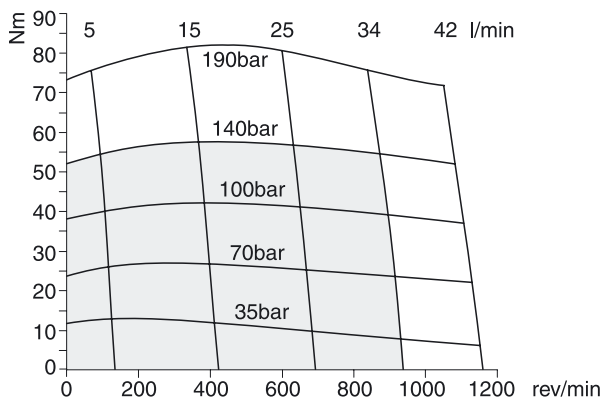

TE/TJ 45

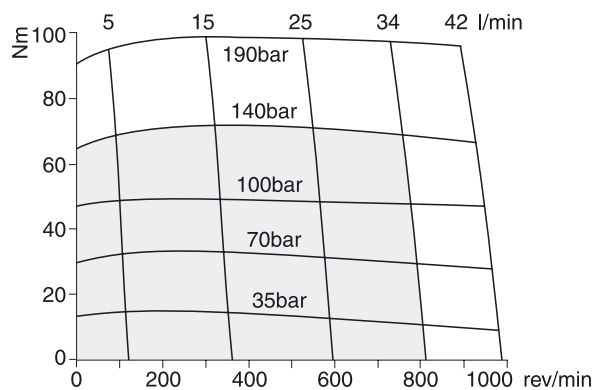

TE/TJ 50

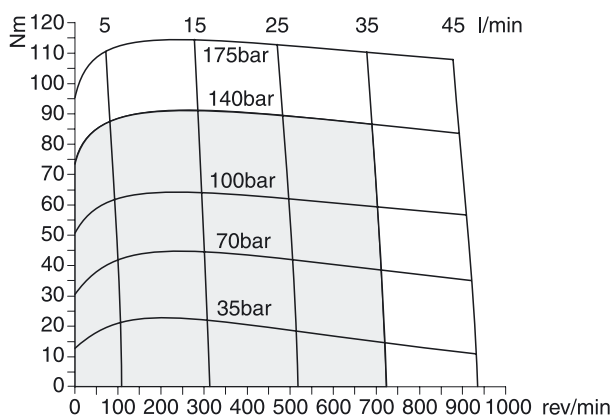

TE/TJ 65

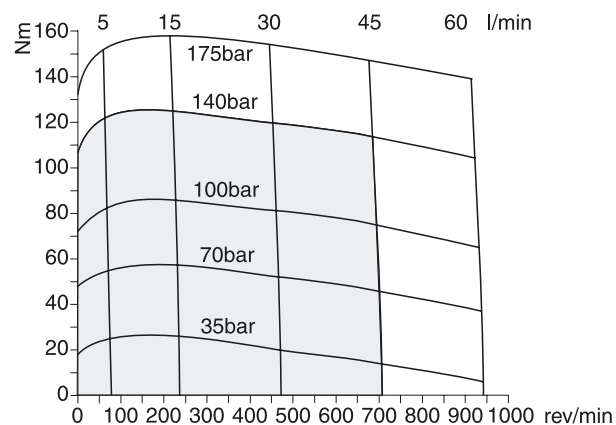

TE/TJ 80

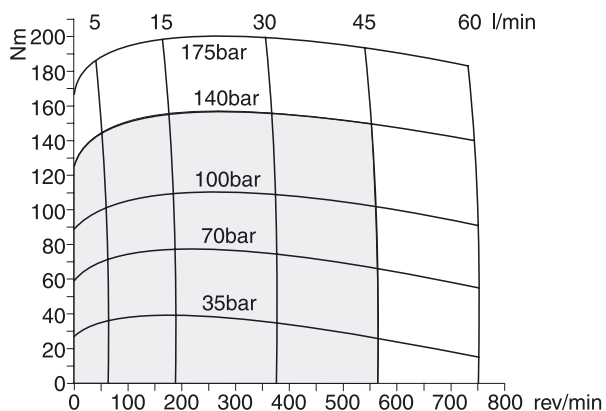

TE/TJ 100

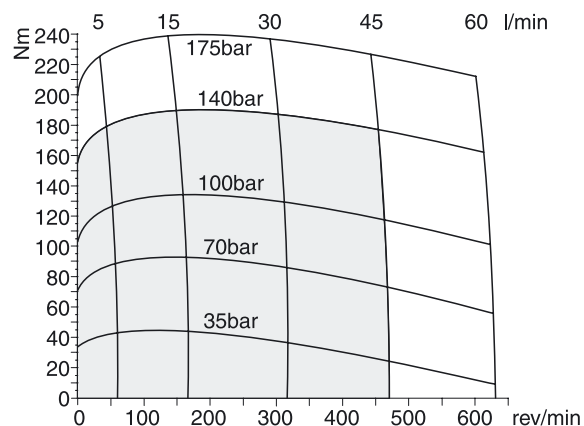

■ Cont. □ Int.

int. =
 Intermittierende Werte maximal 10% von jeder Betriebsminute.
 Fonctionnement interm. 10% max. de chaque minute d'utilisation.
 Intermittent operation rating applies to 10% of every minute.
 Servizio intermittente 10% max di ogni minuto di utilizzazione.

TE/TJ 130

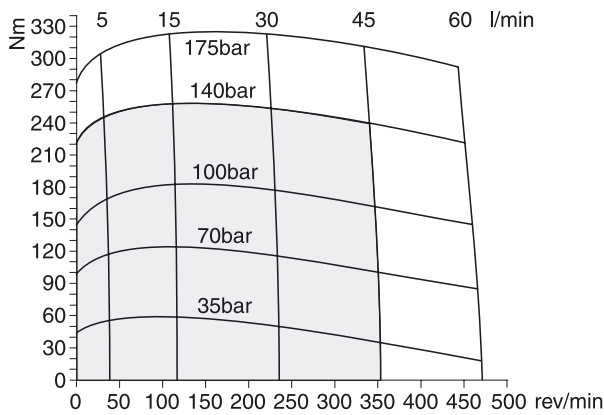

TE/TJ 165

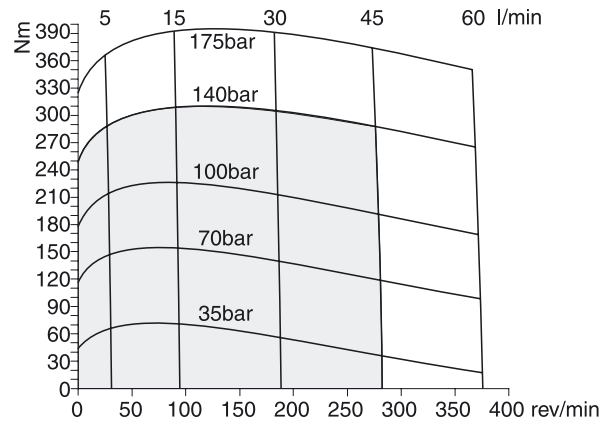

TE/TJ 195

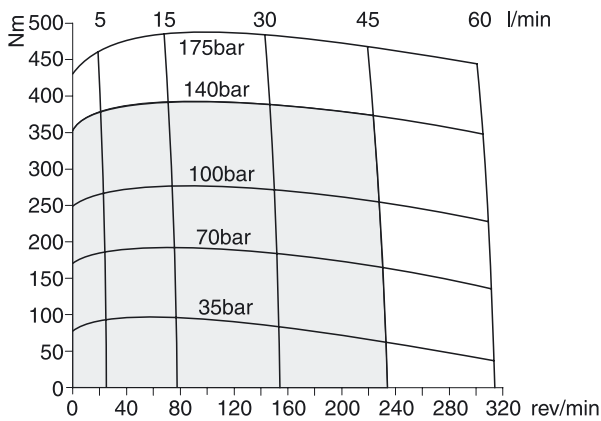

TE/TJ 230

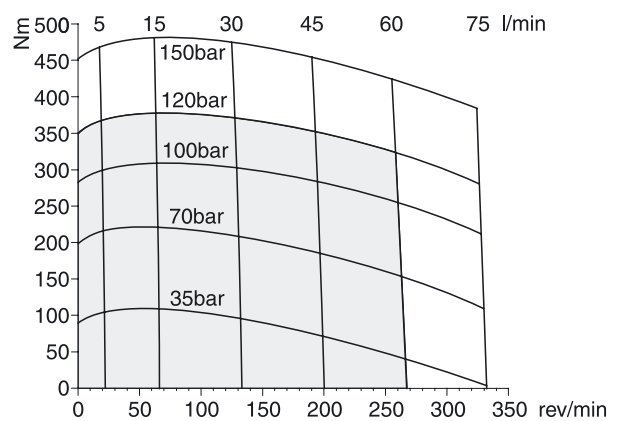

TE/TJ 260

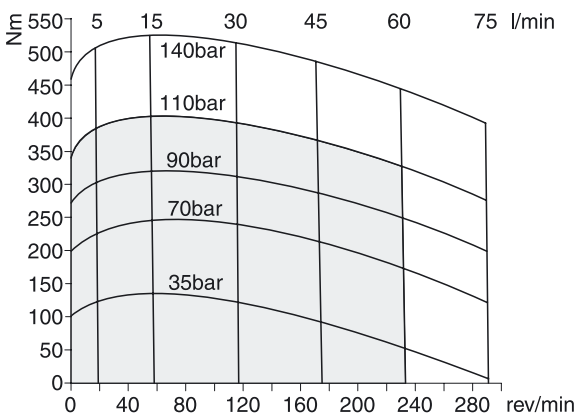

TE/TJ 295

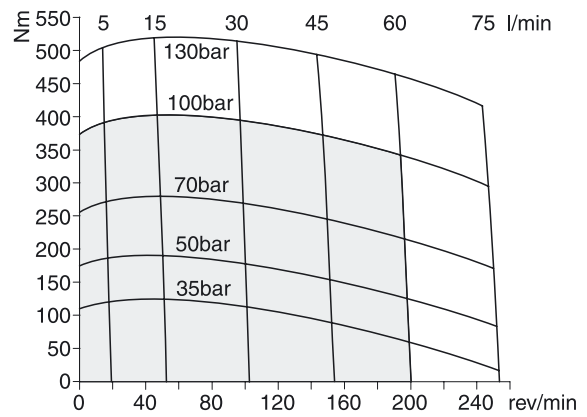

■ Cont.

□ Int.

int. =

Intermittierende Werte maximal 10% von jeder Betriebsminute.
 Fonctionnement interm. 10% max. de chaque minute d'utilisation.
 Intermittent operation rating applies to 10% of every minute.
 Servizio intermittente 10% max di ogni minuto di utilizzazione.

TE/TJ 330

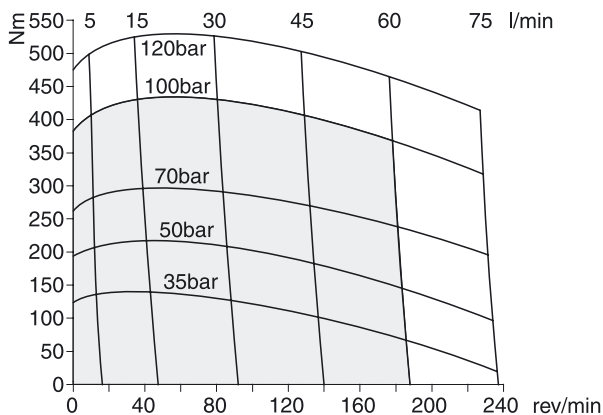

TE/TJ 365

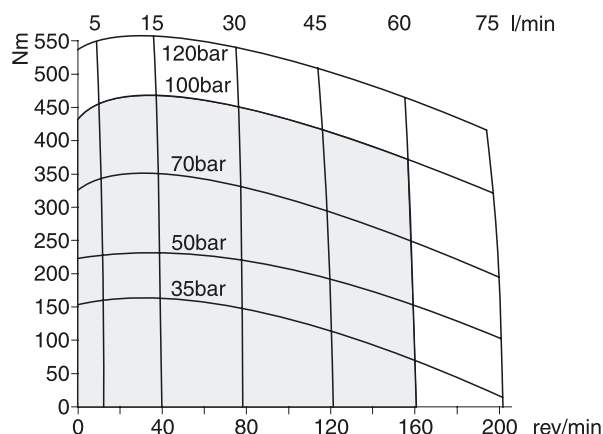

TE/TJ 390

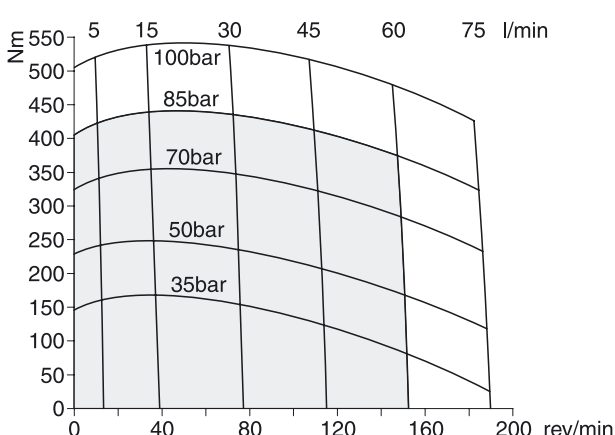

□ Cont. □ Int.

int. =
 Intermittierende Werte maximal 10% von jeder Betriebsminute.
 Fonctionnement interm. 10% max. de chaque minute d'utilisation.
 Intermittent operation rating applies to 10% of every minute.
 Servizio intermittente 10% max di ogni minuto di utilizzazione.

PI 3205 TE-TJ.PMD RH

Beispiel / Example Series TE / TJ230

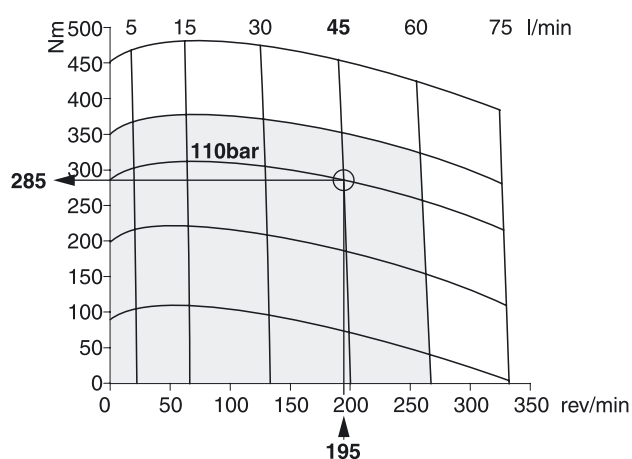

$$\begin{aligned} M_d &= 285 \text{ Nm} & V &= 229.4 \text{ cm}^3/\text{rev} \\ n &= 195 \text{ rev/min} & Q &= 45 \text{ l/min} \\ \Delta p &= 110 \text{ bar} \end{aligned}$$

Volumetrischer Wirkungsgrad (η_{vol})
 Volumetric efficiency
 Rendement volumétrique
 Rendimento volumetrico

$$\eta_{vol} = \frac{n \cdot Y}{Q \cdot 10^3} = \frac{195 \cdot 229.4}{45 \cdot 10^3}$$

$$\eta_{vol} = 0.99$$

Hydraulisch-mechanischer Wirkungsgrad (η_{hm})
 Hydraulic-mechanical efficiency
 Rendement hydro-mécanique
 Rendimento idro-meccanico

$$\eta_{hm} = \frac{M_d \cdot 20 \cdot \pi}{\Delta p \cdot V} = \frac{285 \cdot 20 \cdot \pi}{110 \cdot 229.4}$$

$$\eta_{hm} = 0.71$$

Gesamtwirkungsgrad (η_{ges})
 Overall efficiency
 Rendement global
 Rendimento totale

$$\eta_{ges} = \eta_{vol} \cdot \eta_{hm} = 0.99 \cdot 0.71$$

$$\eta_{ges} = 0.70$$

Leistung P (kW)
 Power P
 Puissance P
 Potenza P

$$P = \frac{M_d \cdot n \cdot \pi}{10^4 \cdot 3} = \frac{285 \cdot 195 \cdot \pi}{10^4 \cdot 3}$$

$$P = 5.8 \text{ kW}$$

TE Code C/D

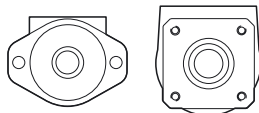

$$L_h = \frac{\left(\frac{357300}{F_R \cdot \left(1.161 + \frac{L}{62\text{mm}} \right)} \right)^{3.3}}{n}$$

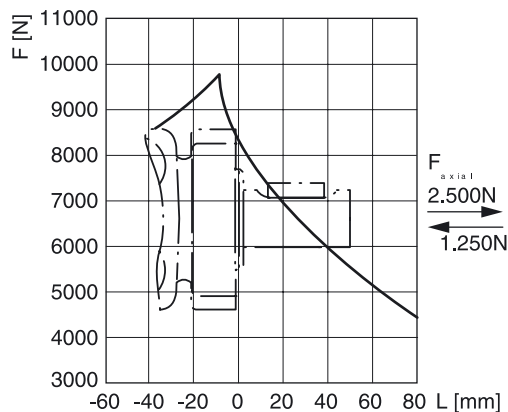

TE Code C

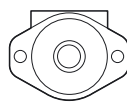

$$L_h = \frac{\left(\frac{357300}{F_R \cdot \left(1.076 + \frac{L}{62\text{mm}} \right)} \right)^{3.3}}{n}$$

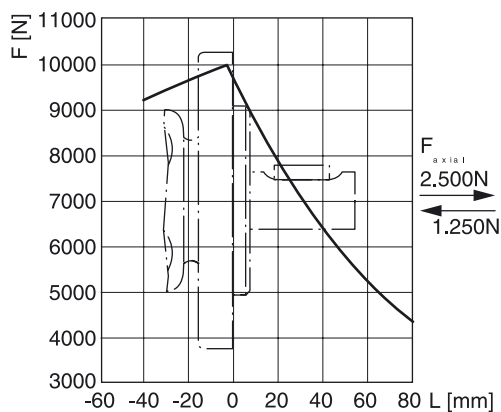

TE Code L

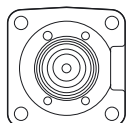

$$L_h = \frac{\left(\frac{357300}{F_R \cdot \left(0.69 + \frac{L}{62\text{mm}} \right)} \right)^{3.3}}{n}$$

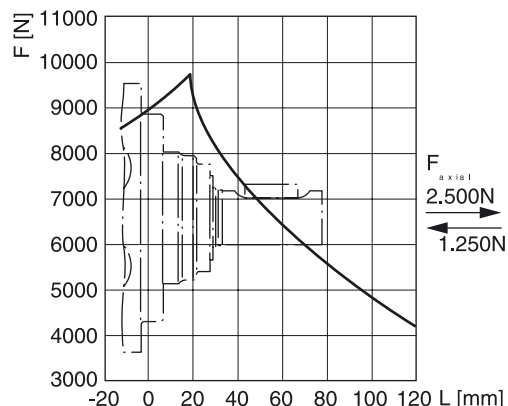

TJ Code H

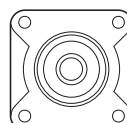

$$L_h = \frac{\left(\frac{840000}{F_R \cdot \left(0.57 + \frac{L}{71\text{mm}} \right)} \right)^{3.3}}{n}$$

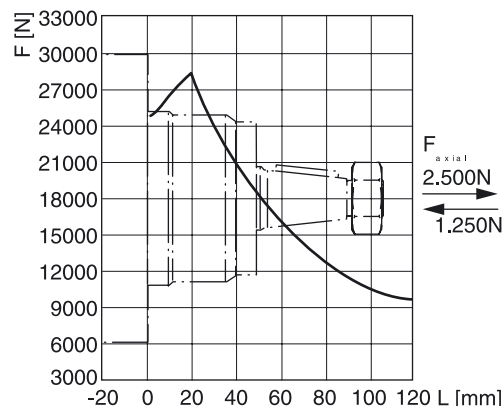

Die Lebensdauer der Radiallager (L_h in Stunden) lässt sich nach folgender Formel berechnen. Die Größe F_R ist durch die mechanische Festigkeit der Abtriebswelle begrenzt (siehe Diagramm). Das Maß "L" ist das Längenmaß vom Gehäuseflansch bis zum Angriffspunkt der Radialkraft F_R .





Life time (L_h in hours) of the radial bearings can be calculated with the following formula. The value F_R is limited by the mechanical strength of the shaft (see diagram). The measurement "L" is the length from the housing flange up to the point of impact of the radial force F_R .

La durée de vie des roulements radiaux (L_h en heures) peut être calculée par les formules suivantes. La grandeur F_R est limitée par les résistances mécaniques de l'arbre de sortie (voir diagramme). La cote "L" est la longueur entre la bride du carter jusqu'au point d'appui de l'effort radial F_R .

La durata dei cuscinetti (L_h in ore) può essere calcolata con la seguente formula. Il valore F_R è limitato dalla resistenza meccanica dell'albero (vedi diagramma). La quota "L" è la distanza tra la flangia del corpo ed il punto di applicazione della forza radiale F_R .

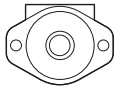
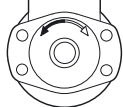
Vorstehende Formeln gelten für eine B10-Lebensdauer.
 The preceding formulas are valid for a B10 duration of life.
 Les formules précédentes sont valables pour une durée de vie B10.
 Le formule precedenti sono valide per una durata della vita B10.

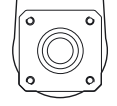
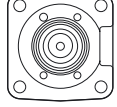
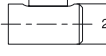
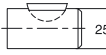
L_h = h
 L = mm
 F_R = F (N)
 n = rev/min

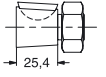
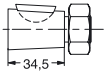
TE									
Series	Schluckvolumen Displacement Cylindrée Cilindrata			Gehäuse Housing Carter Scatola motore	Anschluss Ports Plan de raccordement Conessioni	Welle Shaft Arbre Albero	Drehrichtung Direction of rotation Direction de rotation Direzione di rotazione	Option	
Code	cm ³ /rev							Code	Option
0036	36							AAAB	standard
0045	41							AANC	shuttle valve
0050	50							BBCP ²⁾	internal relief valve 100 bar
0065	66							BBCN ²⁾	internal relief valve 140 bar
0080	82							HAAP	external relief valve 100 bar
0100	98							HAAU	external relief valve 140 bar
0130	130							AAMB ³⁾	stainless steel shaft
0165	163								
0195	196								
0230	228								
0260	261								
0295	293								
0330	326								
0365	370								
0390	392								
Code	Housing							Code	Direction
C								0	 Standard
M								1	
D									
L									
Code	Port							Code	Shaft
W	G 1/2							26	
N ¹⁾	universal port M8x13							10	
Y	rear port G 1/2 axial							41	 6B SAE
								12	
								25	

²⁾ Nicht verfügbar für Anschluss Y
 Not available for port code Y
 Pas disponible pour raccorde-
 ment code Y
 Non Disponibile per connessioni
 codice Y

³⁾ Nur verfügbar für Welle 26
 Only possible with shaft 26
 Possible seulement avec arbre 26
 Possible solo con abbero 26

¹⁾ Nicht verfügbar für
 Gehäuse L
 Not available for housing
 code L
 Pas disponible pour
 carter code L
 Non Disponibile per
 Alloggiamento codice L

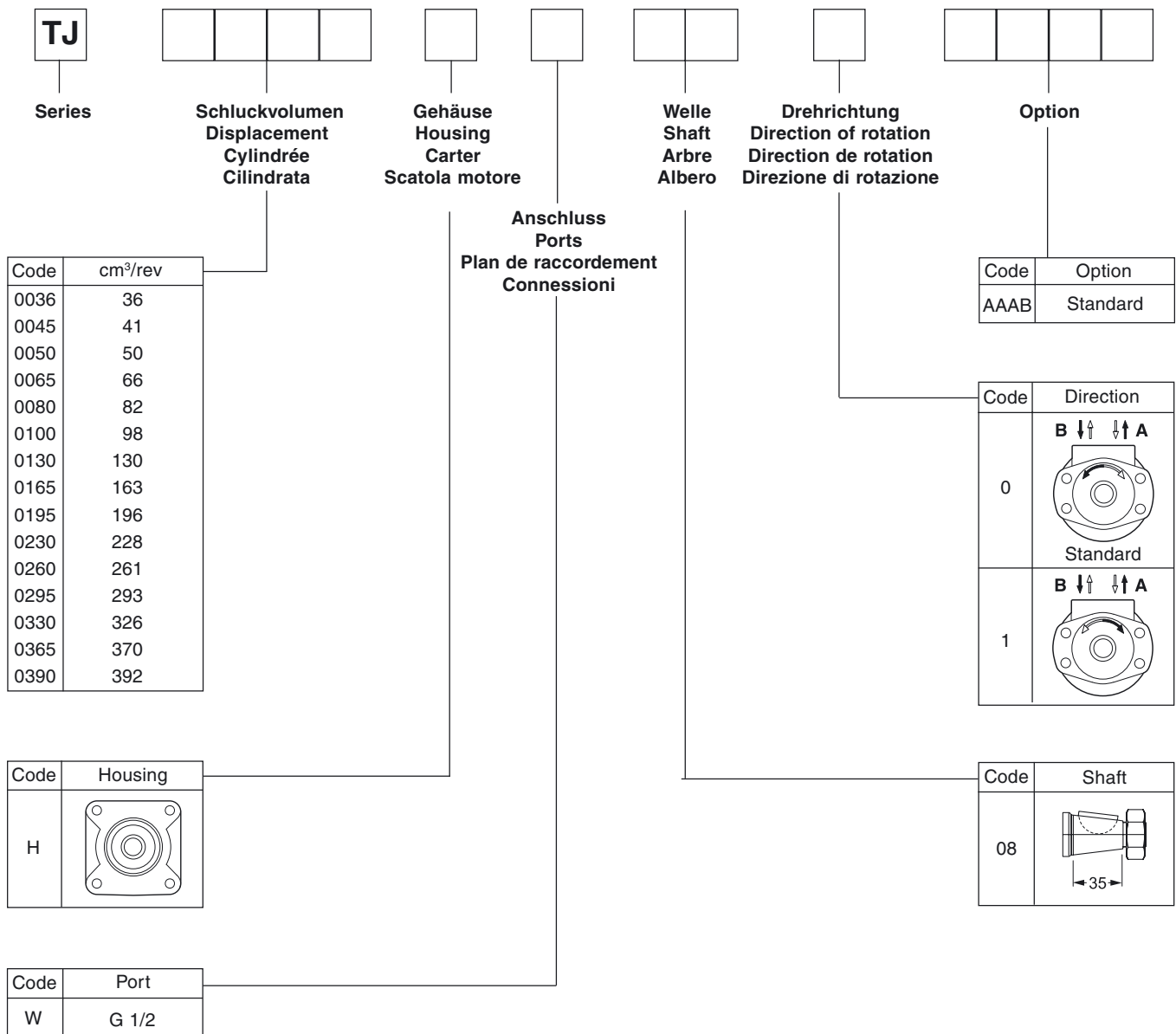

Schockventil / Relief valve / Soupape sécurité / Regolatrice pressione
Extern / external

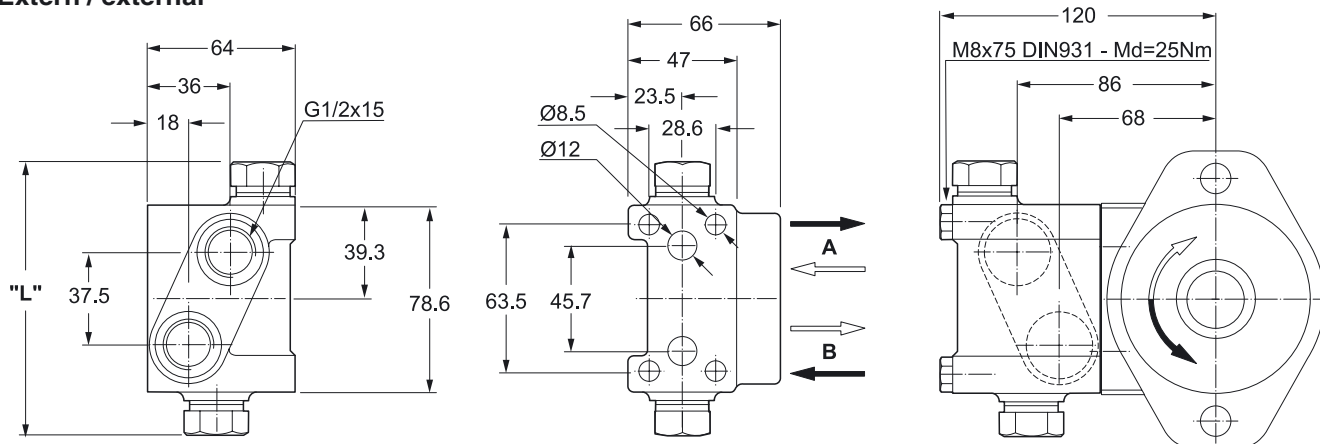

Bestellschlüssel / Ordering code / Système de commande / Sistema di ordinazione

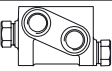
Option code	Shift pressure	Single valve	Single part order no.	Option code	Length "L"
HAAP	100 bar	 Zubehör / Fixtures 4 x M8 x 75mm 2 x O Ring	410017-100	HAAP	110 mm
HAAU	140 bar		HAAU	410017-140	158 mm

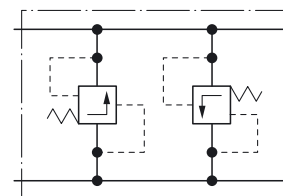

Intern / internal

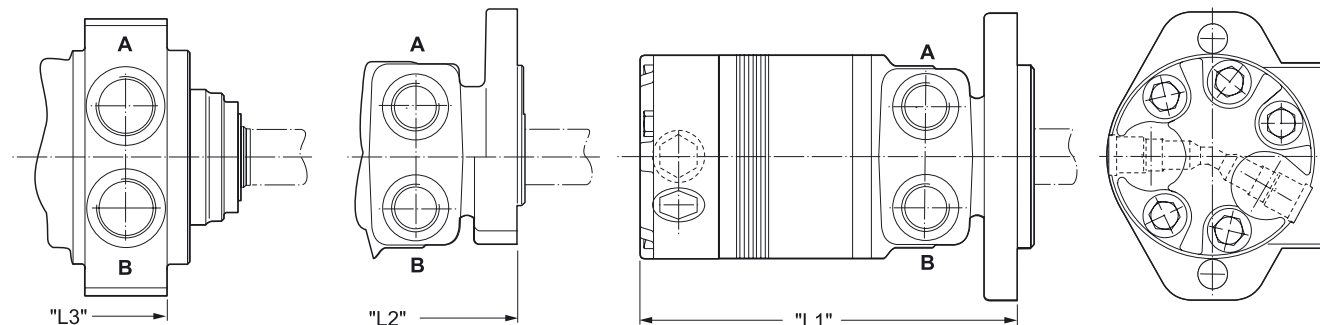

Bestellschlüssel / Ordering code / Système de commande / Sistema di ordinazione

Option code	Shift pressure
BBCP	100 bar
BBCN	140 bar

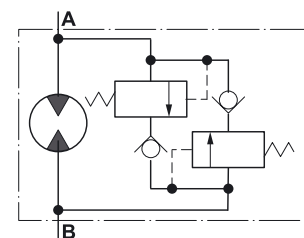

Gewicht / Weight	TE36	TE45	TE50	TE65	TE80	TE100	TE130	TE165	TE195	TE230	TE260	TE295	TE330	TE365	TE390	
Poids / Peso [kg]	7.8	7.9	8.0	8.1	8.2	8.3	8.6	8.9	9.2	9.4	9.7	9.8	10.2	10.5	10.7	
Code	"L1" [mm]	157	159.8	161.8	164.8	168.2	171.2	177.5	183.9	190.2	196.6	202.9	209.3	215.6	223.8	228.6
	"L2" [mm]	163	164.4	166.4	169.4	172.7	175.7	182.1	188.5	194.8	201.2	207.5	213.9	220.2	228.2	233.2
	"L3" [mm]	134	135.5	137.5	140.5	143.5	146.7	153.2	159.5	165.8	172.3	178.6	185.0	191.3	199.4	204.3

Code AANC

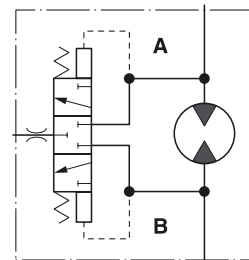
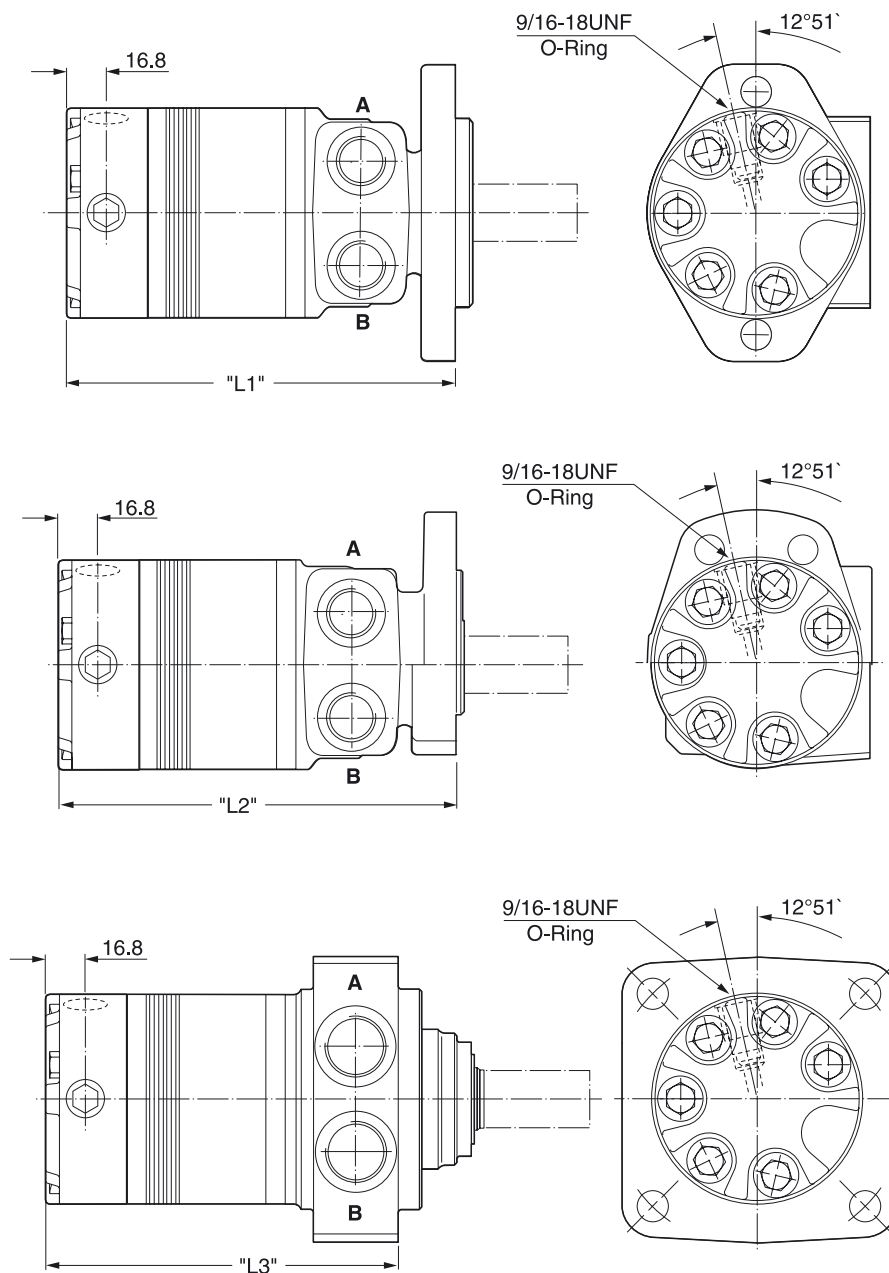

Q=5 l p=9 bar $\dot{v}=39 \text{ mm}^2/\text{s}$

Spülventil für geschlossene Systeme zur Rückführung einer definierten Menge des Niederdrucköls in den Tank zur Abkühlung innerhalb des selben Kreislaufs.

Hot oil shuttle valve allows for diverting of low pressure oil in closed loop applications to be returned to tank, cooler or filter for cooling in the same circuit.

Valve de rinçage pour systèmes fermes pour le retour d'un volume déterminé de fluide basse pression vers le réservoir, un refroidisseur ou un filtre de réfrigération, dans le même circuit.

Una valvola scambiatrice di calore permette di deviare olio a bassa pressione direttamente al serbatoio o allo scambiatore de calore consentendo, nelle applicazioni a circuito chiuso, un miglior raffreddamento dell'olio.

Gewicht / Weight		TE36	TE45	TE50	TE65	TE80	TE100	TE130	TE165	TE195	TE230	TE260	TE295	TE330	TE365	TE390
Poids / Peso [kg]		7.4	7.5	7.6	7.7	7.8	7.9	8.3	8.5	8.8	9.0	9.3	9.5	9.8	10.0	10.3
Code	"L1" [mm]	149	150	152	155	158	161	168	174	180	187	193	199	206	214	219
	"L2" [mm]	153	154	156	159	162	166	172	178	184	191	197	203	210	218	222
	"L3" [mm]	124	125	127	130	134	137	143	150	156	162	168	175	181	189	194

Dieser robuste, wetterfeste Drehzahlaufnehmer arbeitet nach dem Halleffekt. Es werden 30 Rechteckimpulse pro Abtriebswellenumdrehung erzeugt. Durch Erfassung der positiven und negativen Wellenflanken sind 60 Impulse pro Umdrehung möglich. Der Sensor führt zu keiner Leistungsbeschränkung des Motors. Die volle Radiallastkapazität bleibt erhalten.

This rugged, weather resistant speed sensor is a Hall effect device. When externally powered, 30 square wave digital pulses per output shaft revolution are produced. By signal multiplication, 60 pulses per revolution can be obtained. The installation of this economical sensor does not affect the torque or side load capability of the motor into which it is installed.

Un capteur économique pour mesure de la vitesse. Ce capteur robuste et résistant aux intempéries est à effet Hall. Alimenté par une source externe, il fournit 30 impulsions carrées par tour. Par multiplication électronique, on obtient 60 impulsions par tour. Son montage ne modifie pas le couple ni la charge radiale du moteur qui le reçoit.

Sensore di velocità ad effetto Hall, estremamente robusto e resistente alle intemperie. Genera 30 impulsi al giro, con uscita digitale ad onda quadra. Il numero di impulsi può essere elettronicamente raddoppiato. L'utilizzo di questo sensore, non influisce sulle caratteristiche di coppia o di potenza del motore idraulico.

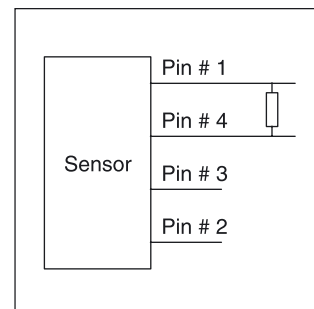
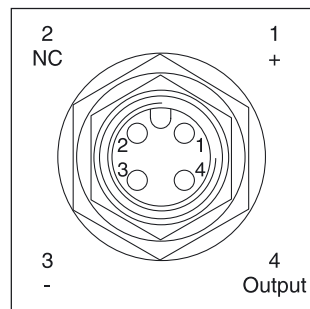

Versorgungsspannung Operating voltage range Courant d'alimentation Tensione di alimentazione	4.5...24 V (DC)
Arbeitstemperatur Operating temperature Température Temperatura di funzionamento	-30°...100° C
Arbeitsfrequenz Operating frequency range Fréquence d'utilisation Frequenza di lavoro	0...10 KHZ
Erforderlicher Laststrom Sink current Courant depeau Corrente di alimentazione	0...20 mA (max.)
Anschluss Connection Raccordement Connessione elettrica	4 Pin (12mm) DIN Standard

Formel Pullup-Widerstand Formula pull-up resistor value Formule valeur pull-up resistor Calcolo resistenza di carico	(0.25 Watt, Tol. 5%) (0.25 Watt, 5% tol.) (0.25 Watt, tol. 5%) (0.25 Watt, toll. 5%)	Spannung/Voltage Courant/Tensione	4.5...24 V	=	Widerstand Resistor Résistance Resistenze	k Ohm
		Laststrom/Sink current Courant/Corrente	0...20 mA			
		Status: aus/State: off Courant: off/Condizione: off (95% +V)				
		+ V			Status: ein/State: on Courant: on/Condizione: on (max. 0.4 V DC)	
		0 V				

Option FSAB

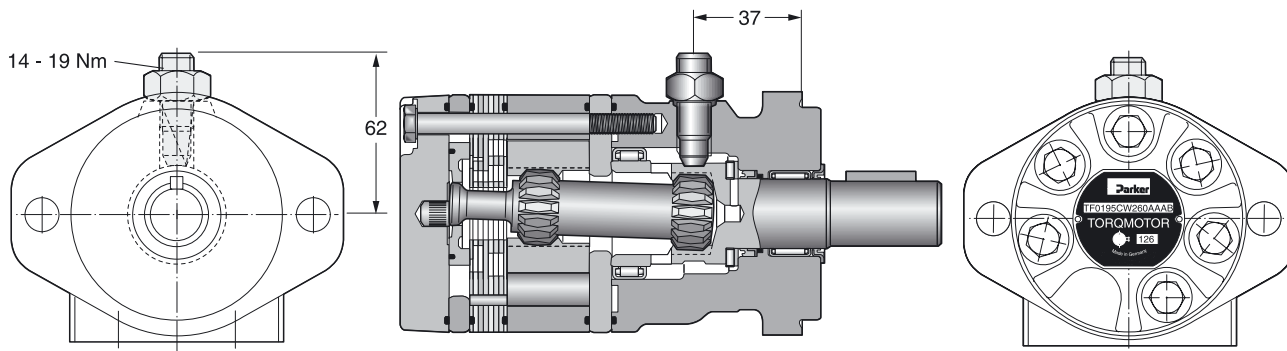

Der Sensor ist gegen Verpolung der Versorgungs-
 spannung, jedoch nicht gegen Kurzschluss geschützt.

Le capteur est protégé contre l'inversion de polarité de la
 tension d'alimentation, mais pas contre les courts circuits.

The sensor has reverse polarity protection but no short
 circuit protection.

Il sensore è protetto contro l'inversione della polarità della
 tensione di alimentazione, ma non contro il corto circuito.

Ordering code

TE	[] [] [] []	[]	[]	[] []	[]	F S A B
Series	Schluckvolumen Displacement Cylindrée Cilindrata	Gehäuse Housing Carter Scatola motore	Anschluss Ports Plan de raccordement Conessioni	Welle Shaft Arbre Albero	Drehrichtung Direction of rotation Direction de rotation Direzione di rotazione	Option

Code	cm ³ /rev
0036	36
0045	41
0050	50
0065	66
0080	82
0100	98
0130	130
0165	163
0195	196
0230	228
0260	261
0295	293
0330	326
0365	370
0390	392

Code	Housing
C	

Code	Port
W	G 1/2
N	universal port M8x13
Y	rear port G 1/2 axial

Code	Direction
0	<div style="text-align: center;"> <p>Standard</p> </div>
1	<div style="text-align: center;"> </div>

Code	Shaft
26	
10	
41	

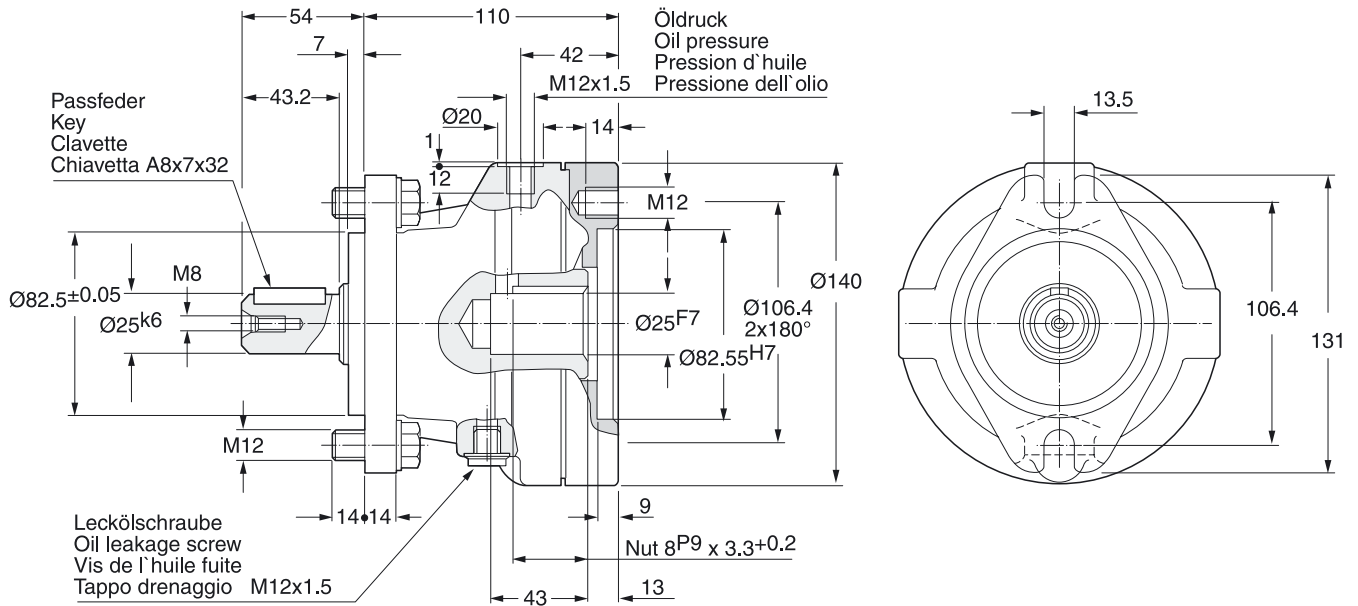

Ordering code

	Einzel-Bremse Single brake Frein Freno	Code		
		49 01 11	49 01 12	49 01 13
Drehmoment (Trockenlauf)/Torque (dry operation) Couple/Coppia statica	stat. Mü Nm	580	400	270
	dyn. Ms Nm	450	320	215
Drehmoment (Nasslauf)/Torque (wet operation) Couple/Coppia statica	stat. Mü Nm	420	290	200
	dyn. Ms Nm	310	225	150
Luftüberdruck/Pressure rating Pression de déblocage/Pressione sbloccaggio	p min. bar	22	15-16	10-11
	p max. bar	320		
Drehzahl/Speed Vitesse de rotation/Velocità di rotazione	n max. U/min	5000		
	n max. rev/min	5000		
	n max tr/min	5000		
	n maxi giri/min	5000		
Hubvolumen/Working Stroke Cylindrée/cilindrata	cm ³ min.	5.0		
	cm ³ max.	10.0		
Massenträgheitsmoment/Mass Moment of inertia Moment d'inertie de masse/Momento di inerzia di massa	kgm ²	0.00065		
Gewicht/Weight/Poids/Peso	kg	8		

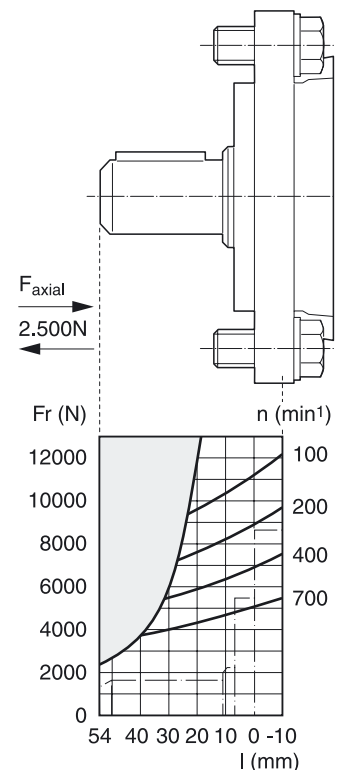

	Motor-Bremse Combi. motor-brake Combi. moteur-frein Assieme motore-freno	Code		
		JAAG	JAAD	JAAB

Zubehör Fixtures Fournitures Part. di fissaggio	2 x M12x50 DIN 933
--	-----------------------

Empfohlen wird die Verwendung eines Hydrauliköls auf Mineralölbasis mit mindestens 0,1% Zinkadditiv als Anti-verschleißzusatz. Vor Einsatz anderer Flüssigkeiten bitten wir um Rücksprache mit unserer Technik.

Die normale Arbeitstemperatur sollte im Bereich von +30°C bis +60°C liegen. Die Maximaltemperatur darf +90°C nicht überschreiten, während die Mindesttemperatur auf -30°C begrenzt ist.

Wird die normale Arbeitstemperatur wesentlich überschritten, wird die Lebensdauer des Öls stark verkürzt.

Die Viskosität im Arbeitstemperaturbereich sollte 20 bis 120mm²/s betragen.

Zweckmäßig ist eine Filtereinheit von 20-50µm.

Die im Katalog angegebenen technischen Daten gelten für den Motorbetrieb.

Arbeitet der Motor als Pumpe, ist das auf die Antriebswelle wirkende Moment auf den angegebenen kontinuierlichen Maximalwert zu begrenzen. Dabei muss ein Vorspanndruck von 5-10 bar, abhängig vom Förderstrom, vorhanden sein (Kavitationsgefahr).

It is recommended to use a mineral based hydraulic oil with minimum 0.1% of zinc as anti-wear additive.

Before using other liquids, please consult our engineering department.

Normal working temperatures should be in the range of between +30°C and +60°C. Maximum temperatures must not exceed +90°C while minimum temperatures should be limited to -30°C.

If normal working temperatures are substantially exceeded this will result in reduced life duration of the oil used.

Viscosity in the range of working temperatures should be 20 to 120mm²/s.

It is advisable to use a filtering fineness of 20-50µm.

The technical data are applicable to motor operation. If the motor is used as a pump, the input torque on the coupling shaft must be limited to the indicated continuous maximum value. For this, an inlet pressure of 5-10 bar must be applied depending on oil flow (danger of cavitation).

Il est recommandé d'utiliser une huile hydraulique à base minérale contenant au minimum 0,1% d'additif zinc comme produit anti-usure.

La température normale d'utilisation devrait être située entre +30°C à +60°C.

La température maximale d'utilisation ne doit pas être supérieure à +90°C, alors que la température minimale est limitée à -30°C.

Lorsque la température de service est largement dépassée, la durée de vie de l'huile est fortement diminuée.

Dans la plage de température de service, la viscosité devrait être située entre 20 et 120mm²/s.

Dans ce but, la filtration est de 20 à 50µm.

Les caractéristiques techniques indiquées dans le catalogue sont considérées pour une utilisation en fonction moteur.

Si le moteur fonctionne en pompe, il faut limiter le couple à la valeur maximale indiquée. Dans ce cas, en fonction du débit, il faut créer une contre-pression de 5 à 10 bar (danger de cavitation).

Come elemento antiusura aggiuntivo si consiglia l'impiego di olio idraulico a base di olio minerale con almeno 0,1% di additivo allo zinco. Prima dell'impiego di altri liquidi si prega di contattare il nostro ufficio tecnico.

La temperatura normale di esercizio dovrebbe essere da +30°C a +60°C.

La temperatura massima non deve superare +90°C, mentre la temperatura minima è limitata a -30°C.

Se la temperatura normale di esercizio viene sostanzialmente superata, la durata dell'olio diminuisce sensibilmente.

La viscosità nel campo della temperatura di esercizio dovrebbe essere da 20 a 120mm²/s.

Si deve prevedere un sistema filtrante per 20...50µm.

I dati sopraesposti sono validi negli impieghi come motore. Se il motore viene usato come pompa, la coppia sull'albero deve essere limitata a quella massima ammessa. Pertanto il motore deve essere pressurizzato da 5...10 bar in funzione della portata d'olio per evitare cavitazione.

Produktübersicht Motor range Gamme de moteurs Serie di motori	Geom. Schluckvolumen Geometric displacement Cylindrée Cilindrata	Max. Drehzahl Max. speed Vitesse de rotation maxi Velocità di rotazione max	Max. Schluckstrom Max. oil flow Portata max	Max. Druckgefälle Max. differential pressure Chute de pression maxi Caduta di pressione max	Max. Eingangsdruck Max. supply pressure Pressione maxi entrée Pressione max in entrata	Max. Drehmoment Max. torque Coppia maxi	Max. Leistungabgabe Max. performance Puissance de sortie maxi Potenza meccanica max
Motor series TE/TJ	cm ³ /U cm ³ /rev	cont / int U/min rev/min	cont / int l/min	cont / int bar	bar	cont / int Nm	cont / int KW
TE/TJ 36	36	930 / 1160	35 / 42	140 / 190	200	55 / 70	8.5
TE/TJ 45	41	810 / 990	35 / 42	140 / 190	200	70 / 100	10
TE/TJ 50	50	725 / 935	35 / 45	140 / 175	200	90 / 115	11
TE/TJ 65	66	705 / 940	45 / 60	140 / 175	200	125 / 160	15
TE/TJ 80	82	560 / 750	45 / 60	140 / 175	200	160 / 200	15
TE/TJ 100	98	470 / 630	45 / 60	140 / 175	200	190 / 240	15
TE/TJ 130	130	350 / 470	45 / 60	140 / 175	200	255 / 320	15
TE/TJ 165	163	280 / 375	45 / 60	140 / 175	200	310 / 395	15
TE/TJ 195	196	235 / 315	45 / 60	140 / 175	200	390 / 480	15
TE/TJ 230	228	265 / 330	60 / 75	120 / 150	200	380 / 480	15
TE/TJ 260	261	230 / 290	60 / 75	110 / 140	200	400 / 525	15
TE/TJ 295	293	200 / 255	60 / 75	100 / 130	200	410 / 520	13
TE/TJ 330	326	185 / 235	60 / 75	100 / 120	200	430 / 530	13
TE/TJ 365	370	150 / 200	60 / 75	95 / 110	200	467 / 558	11
TE/TJ 390	392	152 / 190	60 / 75	85 / 100	200	435 / 540	10

Motor series TF	cm ³ /U cm ³ /rev	cont / int U/min rev/min	cont / int l/min	cont / int bar	bar	cont / int Nm	cont / int KW
TF 80	81	550/730	45/60	200/280	300	215/295	19
TF 100	100	600/750	60/75	160/240	300	210/315	21
TF 130	128	470/580	60/75	140/200	300	240/350	19
TF 140	141	420/530	60/75	140/200	300	250/390	18
TF 170	169	355/440	60/75	140/200	300	330/485	19
TF 190	197	300/380	60/75	140/200	300	380/560	19
TF 240	238	320/420	75/100	140/200	300	460/685	24
TF 280	280	270/350	75/100	140/200	300	550/800	24
TF 360	364	200/260	75/100	130/200	300	590/910	24
TF 405	405	170/230	75/100	130/175	300	650/910	21
TF 475	477	150/200	75/100	115/140	300	680/850	17

Motor series TE/TJ	cm ³ /U cm ³ /rev	cont / int U/min rev/min	cont / int l/min	cont / int bar	bar	cont / int Nm	cont / int KW
TG/TH 140	140	530/710	75/100	200/280	300	400/ 545	33
TG/TH 170	169	440/575	75/100	200/280	300	485/ 670	33
TG/TH 195	195	380/510	75/100	200/280	300	560/ 770	33
TG/TH 240	237	320/420	75/100	200/280	300	685/ 945	32
TG/TH 280	280	270/350	75/100	200/280	300	800/1100	31
TG/TH 335	337	225/290	75/100	200/280	300	980/1350	30
TG/TH 405	405	185/245	75/100	170/240	300	960/1350	27
TG/TH 475	476	160/240	75/115	140/200	300	960/1400	28
TG/TH 530	529	140/215	75/115	140/170	300	1050/1280	23
TG/TH 625	624	120/185	75/115	120/160	300	1040/1360	20
TG/TH 785	786	95/145	75/115	100/140	300	1150/1490	17
TG/TH 960	958	78/119	75/115	70/100	300	925/1390	12

Radiale Wellenbelastung
Side loads
Charges latérales
Carico radiale
TE 7.000 N
TJ 14.000 N

Radiale Wellenbelastung
Side loads
Charges latérales
Carico radiale
TF 16.000 N

Radiale Wellenbelastung
Side loads
Charges latérales
Carico radiale
TG 16.000 N
TH 30.000 N

int. = Intermittierende Werte maximal: 10% von jeder Betriebsminute.
Intermittent operation rating applies to 10% of every minute.

Fonctionnement interm. 10% max. de chaque minute d'utilisation.
Servizio intermittente 10% max di ogni minuto di utilizzazione.

Hydraulics Group Sales Offices

Europe

Austria

Wiener Neustadt
Tel: +43 (0)2622 23501
Fax: +43 (0)2622 66212

Belgium

Nivelles
Parc Industriel Sud-Zone II
Tel: +32 (0)67 280 900
Fax: +32 (0)67 280 999

Czech Republic

Prague
Tel: +420 2 830 85 221
Fax: +420 2 830 85 360

Denmark

Ballerup
Tel: +45 4356 0400
Fax: +45 4373 8431

Finland

Vantaa
Tel: +358 (0)9 4767 31
Fax: +358 (0)9 4767 3200

France

Contamine-sur-Arve
Tel: +33 (0)450 25 80 25
Fax: +33 (0)450 03 67 37

Germany

Kaarst
Tel: +49 (0)2131 4016 0
Fax: +49 (0)2131 4016 9199

Hungary

Budapest
Tel: +36 (06)1 220 4155
Fax: +36 (06)1 422 1525

Ireland

Clonee
Tel: +353 (0)1 801 4010
Fax: +353 (0)1 801 4132

Italy

Corsico (MI)
Tel: +39 02 45 19 21
Fax: +39 02 4 47 93 40

The Netherlands

Oldenzaal
Tel: +31 (0)541 585000
Fax: +31 (0)541 585459

Norway

Ski
Tel: +47 64 91 10 00
Fax: +47 64 91 10 90

Poland

Warsaw
Tel: +48 (0)22 863 49 42
Fax: +48 (0)22 863 49 44

Portugal

Leca da Palmeira
Tel: +351 22 9997 360
Fax: +351 22 9961 527

Slovakia

Ref. Czech Republic

Spain

Madrid
Tel: +34 91 675 73 00
Fax: +34 91 675 77 11

Sweden

Spånga
Tel: +46 (0)8 597 950 00
Fax: +46 (0)8 597 951 10

United Kingdom

Watford (industrial)
Tel: +44 (0)1923 492 000
Fax: +44 (0)1923 256 059
Ossett (mobile)
Tel: +44 (0)1924 282 200
Fax: +44 (0)1924 282 299

International

Australia

Castle Hill
Tel: +61 (0)2-9634 7777
Fax: +61 (0)2-9899 6184

Canada

Milton, Ontario
Tel: +1 905-693-3000
Fax: +1 905-876-0788

China

Beijing
Tel: +86 10 6561 0520
Fax: +86 10 6561 0526

Asia Pacific Group

Hong Kong, Kowloon
Tel: +852 2428 8008
Fax: +852 2425 6896

India

Mumbai
Tel: +91 22 7907081
Fax: +91 22 7907080

Japan

Tokyo
Tel: +(81) 3 6408 3900
Fax: +(81) 3 5449 7201

Latin America Group

Brazil
Tel: +55 12 3954-5100
Fax: +55 12 3954-5266

South Africa

Kempton Park
Tel: +27 (0)11-392 7280
Fax: +27 (0)11-392 7213

USA

Cleveland (industrial)
Tel: +1 216-896-3000
Fax: +1 216-896-4031
Lincolnshire (mobile)
Tel: +1 847-821-1500
Fax: +1 847-821-7600

Parker Hannifin is the world's premier supplier of motion and control systems and solutions, with sales and manufacturing facilities throughout the world. For product information and details of your nearest Parker sales office, visit us at www.parker.com or call free on 00800 2727 5374.



Catalogue HY11-3205/EU
03/04 LIM

© Copyright 2004
Parker Hannifin Corporation
All rights reserved.